

Modelling, Testing and Economic Analysis of a Small-Scale Hybrid Wind-Photovoltaic-Battery System Installation

A. D. Karlis and D. P. Papadopoulos

Electrical Machines Laboratory
Department of Electrical & Computer Engineering
Democritus University of Thrace
Xanthi, 67100 Greece
Phone: +30 2541 079722, +30 2541 079721 fax: +30 2541 027955,
e-mail: akarlis@ee.duth.gr, dpapadop@ee.duth.gr

Abstract. In this paper the performance of a practical small-scale hybrid Wind-Photovoltaic-Battery system installation is thoroughly investigated. The system has been installed on the roof of the Electrical Engineering Laboratory Building in Xanthi, Greece and on-site measurements of the main electrical quantities of this system are automatically monitored. A meteorological system has also been installed on the top of the same building and sufficient wind, solar, etc., measurements are continuously taken and processed/evaluated for the purpose of the present paper.

In order to thoroughly evaluate energy wise this installation, a computer program was developed with which the main subsystems of this hybrid system were modelled and practical simulations were performed to technically and economically assess its steady state performance under different types of operation (i.e. autonomous or grid connected mode). Using this program, appropriate economical indices were computed in a systematic manner to examine the economic viability and exploitation of a power system of this type. In addition associated non-financial positive attributes were evaluated, i.e. local/national environmental and socio-economic development impacts.

Key words

Small-scale hybrid power systems, wind generators, photovoltaics, batteries.

1. Introduction

Stand-alone and interconnected hybrid Wind/Photovoltaic systems have been extensively investigated the last few decades (since the 70's) and considered as attractive and alternate, or preferred power sources for sites with sufficient wind and solar energy potential, because this combination, among other things, may lead to a minimization of storage and reserve requirements and hence to the overall cost reduction of the power system. Various methodologies have been developed [1] for optimally sizing the combination of batteries and Photovoltaics in Wind/Photovoltaic hybrid

systems and the results have shown that this procedure depends on the particular site, load profile, and the desired reliability of the hybrid system.

Linear programming models have been developed [2] for the optimal design of hybrid Wind/Photovoltaic power systems for either interconnected or autonomous operation in order to study the applicable interaction among socio-economic, operational and environmental factors.

Other extended studies [3, 4] have shown that it is technically feasible to introduce small-scale, grid-connected Wind and/or Photovoltaic systems, with or without battery storage. Techno-economic evaluation of identifiable Wind and/or Photovoltaic system installations has been performed [4, 5] and validated through actual measurements.

Finally, analytical models have been developed [6], aiming to predict the performance of hybrid Photovoltaic (PV)– Wind Generator (WG)– Battery systems, in order to determine the effective contribution of each Renewable Energy Source (RES) to the load.

2. Techno-economic assessment procedure

A computerized techno-economic assessment procedure is developed and used in the preliminary evaluation of the technical feasibility and financial viability of potential RES installations. A simplified flowchart of the proposed general and systematic techno-economic procedure for wind, photovoltaic and hybrid wind/photovoltaic power plants is shown in Fig.1.

The developed computer program for evaluating the energy potential of specific RES installations is based on the following the procedure: During the first step, the user must systematically collect basic information concerning the site to be studied, such as:

- Energy/Power demand,
- Renewable Energy Resources availability.

In the next step, the user selects the combination of the exploitable RES. Then, taking into account pertinent parameters of the RES to be investigated, a common procedure may be followed for the purposes of the techno-economic assessment. At the beginning of this procedure a reliable renewable energy survey is conducted using the data collected in the first step. Then, the user of the program is able to select more accurately the most promising site for investigation/exploitation. The next step of this procedure pertains to the selection/matching of the type and size of the electromechanical equipment to the available RES potential and expected load to be served. Based on the above, one can evaluate the expected annual energy production of the site.

The techno-economic assessment tool takes into account the various modes of operation of a possible RES power plant, i.e autonomous or interconnected - with the national grid - mode of operation. If the RES power plant is supposed to operate in parallel with the national grid then the end user of the installation should decide whether to operate the plant in **self-producer mode** or in **independent producer mode**.

The next step refers to the pertinent economical data (i.e. costs, subsidies, bank loans, inflation, etc.), which are processed and economic analysis of the anticipated RES project is made. A number of different economic and financial feasibility indices (e.g. **Internal Rate of Return**, **Net Present Value**, **Benefit to Cost Ratio**, **Pay-Back Period**, **Cost of Energy** etc.) are calculated and the results are presented.

The previous step of the developed procedure is of utmost importance, and perhaps crucial, for the decision maker for a possible investment. If the economic analysis is proven to be non-favourable then the procedure stops there, since the investment under these circumstances should not be considered. On the other hand, if the results are encouraging, then the user can perform a sensitivity analysis to find which system parameter(s) is critical or crucial to the financial investment viability of the examined project, in order to help the decision-maker to assess and thus avoid possible investment risks. At this point, the design of the project may be optimised by the computer program.

Finally, in the last step, other attributes of the possible RES project may be assessed, such as environmental and socio-economic impacts associated with the RES project under investigation. The burning of coal or diesel for energy production releases excessive pollutants to the atmosphere, i.e. CO₂, NO_x, SO₂, particulates etc., which are avoided when RES are used for the same purpose. The conventional fuel being replaced by the RES use is estimated in terms of tons of oil equivalent (TOE) or avoided tons of lignite or Nm³ of natural gas.

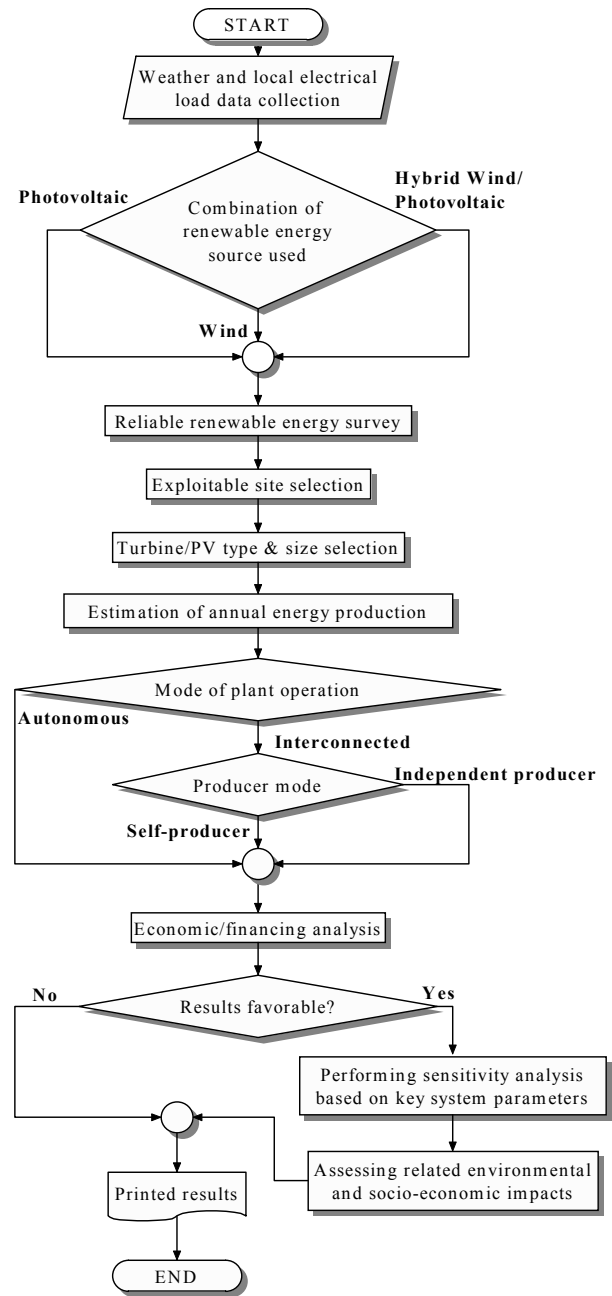

Fig. 1. Simplified flowchart of computational techno-economic procedure

3. System modelling - statistics

A small-scale hybrid Wind-Photovoltaic-Battery system, as mentioned before, has been installed on the roof of the Electrical Engineering Laboratory Building in Xanthi, Greece and on-site measurements of the main electrical quantities of this system are automatically monitored. The system, shown in Fig. 2, consists of a Brushless Permanent Magnet Wind Generator (69 W at 10 m/sec), which gives a DC current charging a 12/24 V battery bank to supply appropriate equipment. The power curve of this generator is presented in Fig. 3.

The Photovoltaic module is composed of 36 polycrystalline silicon cells, connected in series, with the following main characteristics:

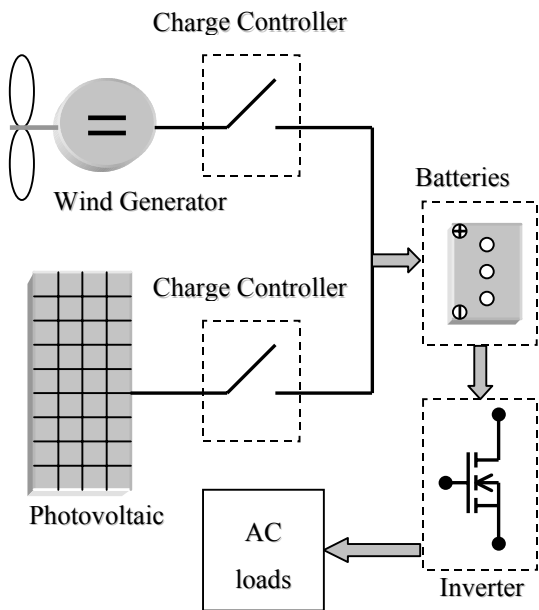

Fig. 2. Installed Wind/Photovoltaic hybrid system

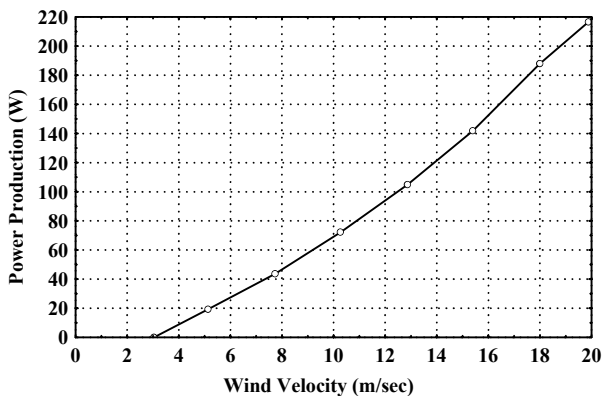

Fig. 3. Wind Generator power curve

TABLE I. – Characteristics of the Photovoltaic module

Peak Power	Pm (W)	67,6
Short Circuit Current	Isc (A)	4,6
Open Circuit Voltage	Voc (V)	21,2
NOCT/°C		45

Additionally, two lead-acid batteries with 12V and 72Ah nominal quantities were installed. The batteries are connected in parallel and charged from the two power sources (i.e. the Wind generator and the Photovoltaic) via two similar charge controllers (shunt type). Finally, a single – phase inverter (with output 230V, 50Hz) is used to supply suitable AC loads.

A meteorological system has also been installed in the same premises and sufficient wind, solar, etc. measurements are continuously recorded.

In order to thoroughly examine the performance of each of the RES and of the overall hybrid system the data, obtained from the meteorological system, were statistically processed.

A. Wind data

The most important statistical parameters of the collected wind data are presented in Table II. The wind speed probability and the respective Weibull distribution of the collected wind data are presented in Fig. 4. As it is shown, the main part of the wind speeds falls between 1 and 5 m/sec. Generally speaking it is clear that the site is not of the best in terms of wind energy potential. The Weibull distribution parameters for the measured wind data are estimated using the maximum likelihood method [4], which is based on the following equations:

$$k = \left(\frac{\sum_{i=1}^n v_i^k \ln(v_i)}{\sum_{i=1}^n v_i^k} - \frac{\sum_{i=1}^n \ln(v_i)}{n} \right)^{-1} \quad (1)$$

$$c = \left(\frac{1}{n} \sum_{i=1}^n v_i^k \right)^{1/k} \quad (2)$$

where: c is the distribution factor, k is the shape factor, v_i is the wind speed in time step i , and n is the number of nonzero wind speed data points. The above equations explain why the shape factor of the Weibull distribution in Table II is the same in the various heights.

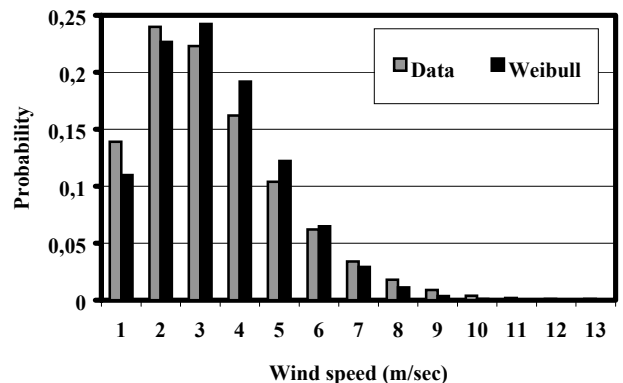

Fig. 4. Wind speed probability and Weibull distribution

Fig. 5 shows the wind rose shape relating to the site and it is clear that the winds are mostly directed towards the North.

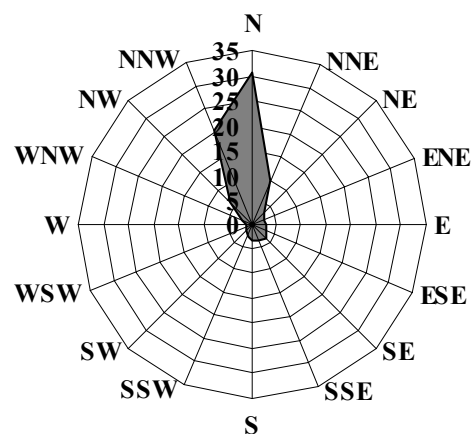

Fig. 5. Annual wind direction frequency distribution

TABLE II. – Wind data assessment at various heights of the site under investigation using the developed program

Height (m)	Mean value (m/sec)	Standard deviation	Mean cubic value	Weibull distribution factor c	Shape factor k
10	2,521707	1,422739	3,240644	1,847915	2,839085
20	2,89668	1,634298	3,722522	1,847915	3,261252
30	3,141368	1,77235	4,03697	1,847915	3,536736
40	3,327412	1,877316	4,276055	1,847915	3,746195
50	3,479273	1,962996	4,471212	1,847915	3,917169

B. Solar data

In order to evaluate the performance of a tilted Photovoltaic array the solar insolation must be determined. The evaluation of the daily mean total solar insolation (for each month) on a tilted PV array with south orientation was made using the Liu – Jordan mathematical model [5].

According to this model, the daily mean total solar insolation (for each month) on a horizontal surface \bar{H} could be expressed as a portion of the extraterrestrial solar insolation on the horizontal surface \bar{H}_0 :

$$\bar{K}_T = \frac{\bar{H}}{\bar{H}_0} \tag{3}$$

where:

$$\bar{H}_0 = \frac{1}{(m_2 - m_1)} \cdot \sum_{N=m_1}^{m_2} (H_0)_N \tag{4}$$

and \bar{K}_T is the clearness index, m_1 and m_2 are the days in the beginning and the end of each month, while $(H_0)_N$ is the extraterrestrial solar insolation on the horizontal surface during the N day of the year:

$$(H_0)_N = \frac{24}{\pi} \cdot SC \cdot \left[1 + 0,033 \cos\left(\frac{2\pi N}{365}\right) \right] \cdot \left[\cos L \cdot \cos \delta \cdot \sin \omega_s + \frac{2\pi \omega_s}{360} \sin L \cdot \sin \delta \right] \tag{5}$$

SC is the solar constant and ω_s is the sunset hour angle on horizontal surface and it is calculated as follows:

$$\cos \omega_s = -\tan L \cdot \tan \delta \tag{6}$$

The daily mean total solar insolation (of each month) on a tilted PV array \bar{H}_T , is given by the equation:

$$\bar{H}_T = \bar{R} \cdot \bar{H} = \bar{R} \cdot \bar{K}_T \cdot \bar{H}_0 \tag{7}$$

The parameter \bar{R} , is the tilt factor and is calculated by:

$$\bar{R} = \left(1 - \frac{\bar{H}_D}{\bar{H}} \right) \bar{R}_B + \frac{\bar{H}_D}{\bar{H}} \cos^2\left(\frac{s}{2}\right) + a \sin^2\left(\frac{s}{2}\right) \tag{8}$$

where \bar{H}_D is the daily mean diffuse solar insolation (for each month), \bar{R}_B is the tilt factor for the daily direct solar insolation, while α is the ground reflectivity, with

values between 0,2 and 0,7 depending on the type of the ground.

C. I-V characteristic of the Photovoltaic module

The evaluation of the $I-V$ characteristic of a PV module for irradiance G and cell temperature T_{cell} levels, different from the standard test conditions (STC), is based on the following equations:

$$I(V) = I_{SC} \left\{ 1 - C_1 \left[\exp\left(\frac{V + \Delta V}{C_2 \cdot V_{OC}}\right) - 1 \right] \right\} + \Delta I \tag{9}$$

where: $\Delta I = \alpha \cdot \left(\frac{G}{G_{ref}}\right) \cdot \Delta T + \left(\frac{G}{G_{ref}} - 1\right) \cdot I_{SC}$ (10)

$$\Delta V = -\beta \cdot \Delta T - R_s \cdot \Delta I \tag{11}$$

$$\Delta T = T_{cell} - T_{ref} \tag{12}$$

- T_{cell} : the cell temperature ($^{\circ}C$),
- T_{ref} : the reference temperature ($^{\circ}C$),
- G_{ref} : the reference irradiance (W/m^2),
- α : the current change temperature coefficient at reference insolation ($A/^{\circ}C$),
- β : the voltage change temperature coefficient at reference insolation ($V/^{\circ}C$),
- R_s : the module series resistance (Ohm).

The efficiency of a solar cell is a function of the cell and the reference Temperature:

$$\eta(T_{cell}) = \eta(T_{ref}) \cdot (1 - \mu \cdot (T_{cell} - T_{ref})) \tag{13}$$

where $\eta(T_{ref})$ is the efficiency of the solar cell at the reference temperature, and μ is the temperature coefficient of the solar cell (in $\%/^{\circ}C$). The cell temperature is given by:

$$T_{cell} = \frac{G}{G_{NOCT}} (NOCT - T_{a,NOCT}) \left(1 - \frac{\eta_c}{\tau \alpha} \right) + T_a \tag{14}$$

$$T_{a,NOCT} = 20^{\circ}C$$

$G_{NOCT} = 800 W/m^2$ for a wind speed of 1 m/sec.

$NOCT$ is the nominal operating cell temperature.

α is the solar absorbance of the array and

τ is the solar transmittance of PV array cover.

The mean monthly electrical energy available from the PV array is calculated by:

$$E_{out} = \eta \cdot \eta_b \cdot \eta_i \cdot \eta_w \cdot \eta_c \cdot E_{in} \cdot A \text{ (kWh)} \tag{15}$$

where $\eta, \eta_b, \eta_i, \eta_w, \eta_c$ is the solar cell, batteries, inverter, wiring and charger efficiency, respectively, and A is the PV array surface area.

D. Assessment of RES potential

A statistical process of the weather data, needed to estimate the RES annual energy production, is presented in Table III.

TABLE III. – Mean monthly values of wind velocity, irradiance and Temperature for year 2002

Month	\bar{U} (m/sec)	\bar{G} (W/m ²)	\bar{T} (°C)
Jan	2,50	118,17	5,84
Feb	2,33	166,57	11,31
Mar	2,55	172,75	11,87
Apr	2,31	181,61	14,15
May	2,32	253,84	20,18
Jun	2,57	263,46	25,02
Jul	2,78	259,91	27,16
Aug	2,65	236,11	25,22
Sep	2,56	195,24	21,36
Oct	2,19	172,73	17,00
Nov	2,47	118,69	12,98
Dec	2,78	70,67	5,75

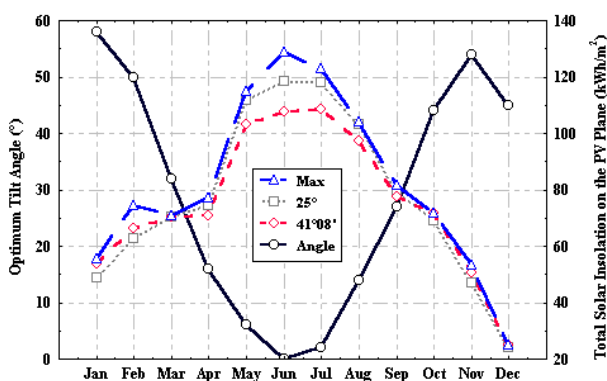

Fig. 6. Optimal tilt angle of the PV array and incident total solar insolation on PVs plane

The implementation of equations (3) –(8), involving also the tilt angle of the PV array, gave the results shown in Fig. 6.

The continuous line shows the optimum tilt angle in order to receive each month of the year the maximum incident energy on the surface of the PV. If the array is tilted every month to its optimum angle, then the energy is 980,066 kWh/m² for the year 2002 (line with the indication Max). If the array is to be tilted to a permanent angle, then the angle, with maximum energy (925,784 kWh/m²), for the whole year is 25°. The placement of the PV array to a tilt angle equal to the latitude of the city of Xanthi (41°08') gives a better-balanced curve of the incident energy (902,503 kWh/m²) during the year.

The Solution of equations (13) – (15) results to a net expected annual energy production of **40 kWh** from a single PV array.

For illustration purposes a few cases of WG installation were assessed and the respective results are presented in Table IV. The most promising case concerns a 55 kW WG having a capacity factor of approximately 10% (using either the Weibull distribution or the real data at the site under investigation).

From the operation of the installed WG, type Rutland 913, approximately **46 kWh** (total net annual energy production for the year 2002) are expected, taking into consideration the total system efficiency.

In order to study the system performance and efficiency, and compare the expected annual energy production to the actual obtained one, measurements are taken, concerning the electrical quantities of the hybrid system installation. The system is operating in an autonomous mode, charging the batteries and supplying occasionally three AC loads, i.e. 59 W, 61,4 W and 70,8 respectively.

In Fig. 6 (a) and (b) measurements of the current, voltage and power production of the PV array and the WG respectively are presented. It is clear that during the hours from 9 a.m. to about 3 p.m. it is the PV array that contributes mainly to the battery charging, while the WG performs better during the night hours, i.e. from 8 p.m. to about 12 midnight.

TABLE IV. – Main technical characteristics of various wind turbines and expected annual energy production with respect to the site

Manufacturer	Nominal Power (kW)	Hub Height (m)	Weibull Energy (kWh)	Weibull Capacity Factor	Data Energy (kWh)	Data Capacity Factor
MICON 55-11	55	22	44.866,942	0,093	44.965,639	0,12
ENERCON E-18 80	80	50	47.773,64	0,068	57.854,433	0,083
SÜDWIND S,1245 45	45	50	24.620,214	0,062	30.156,908	0,077
VESTAS V27 150-50	150	30	65.824,358	0,05	87.845,124	0,067
NORDTANK 45-11	45	20	22.533,334	0,057	28.073,691	0,065
RUTLAND 913	69 W at 10 m/sec	20*	48,8667		68,4	

*including the building height

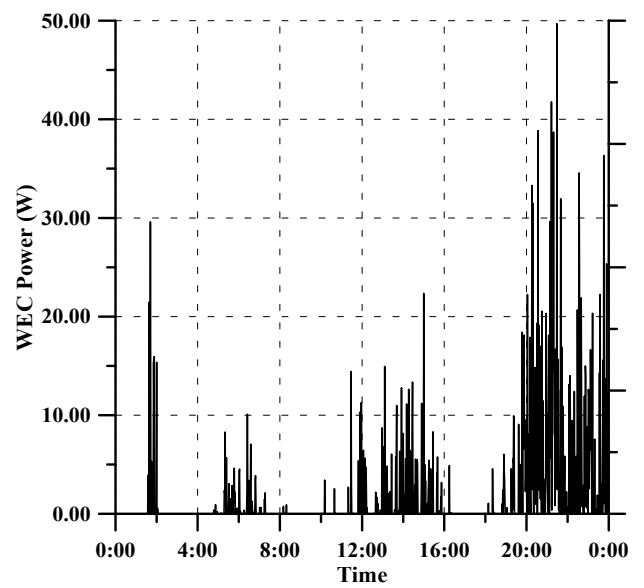
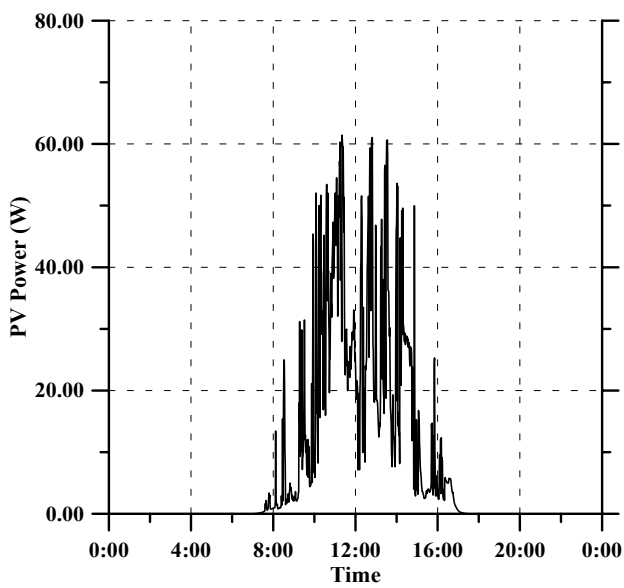
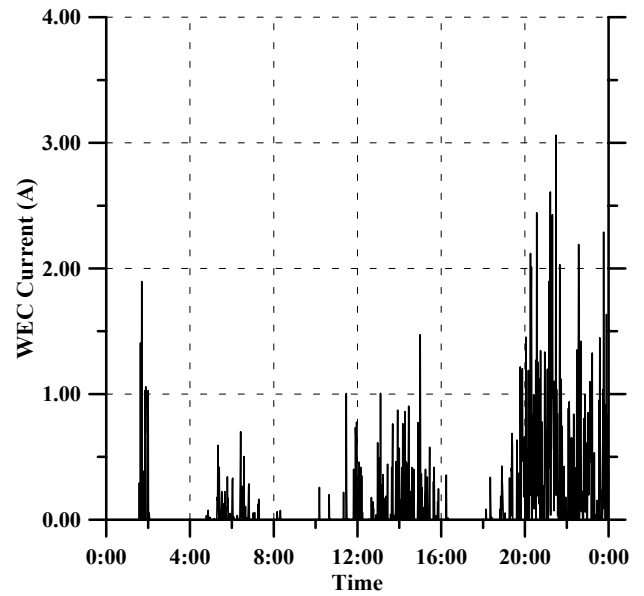
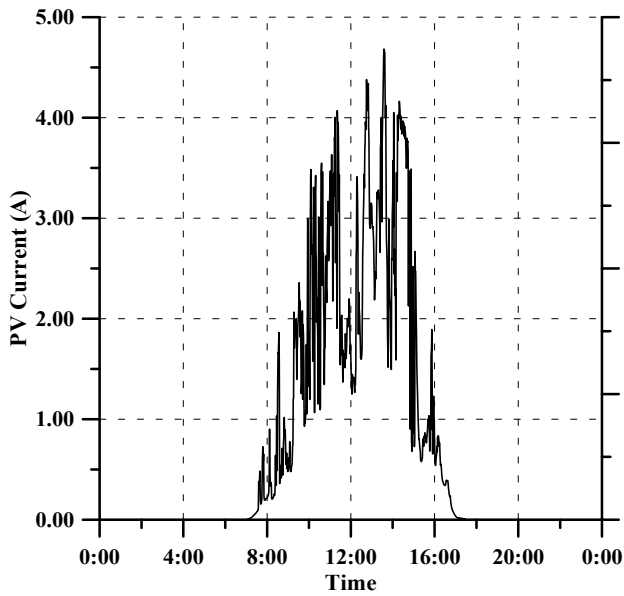
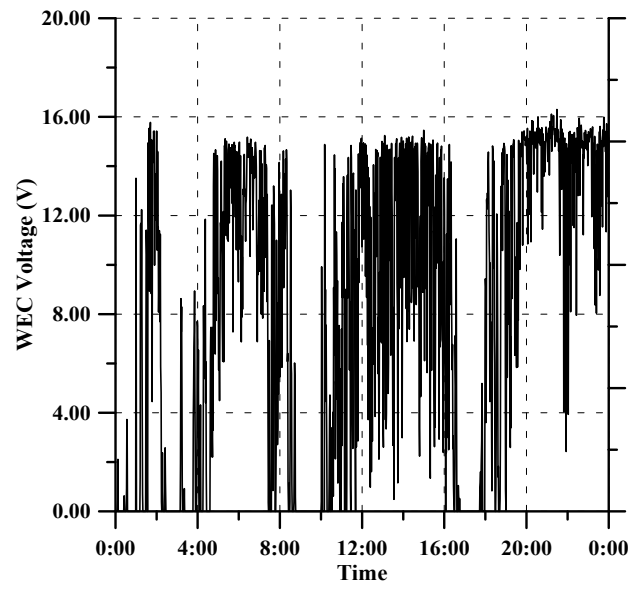
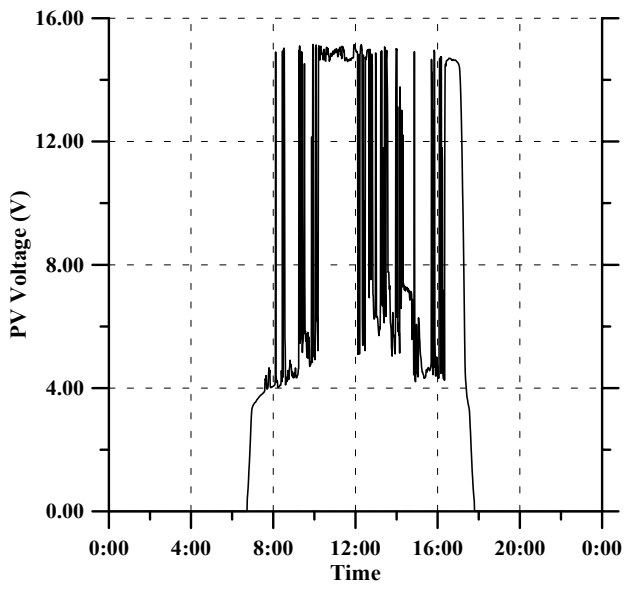

(a)

(b)

Fig. 6. Actual Voltage, Current and Power measurements ((a) the photovoltaic and (b) the wind generator) for a typical day

E. Economic assessment

The RES potential at the site under investigation has the features presented in Figs. 4, 5 and Table III. For illustration purposes and for the program validation a case study, using a non-installed WG and PV on the site, has been examined, i.e. the corresponding renewable energy potential has been assessed for the purpose of a preliminary study for a possible private investment in the Thrace region of Greece (where Democritos University is located) in order to operate as an **independent producer**.

Using the developed program, appropriate economical indices have been evaluated in order to examine the economic viability of such a power system. In addition associated non-financial attributes have also been assessed, i.e. local/national environmental and socio-economic impacts. The present study took also into account the existing tariffs for selling electrical energy to the national grid and the pertinent Greek energy and development laws.

The possible investment is considered to follow the most optimistic financing scenario for the Thrace region, i.e. 35% of the total investment cost is covered by own capital, 45% is by national subsidy, and 20% is provided through a bank loan. 45% of the loan interest (7% for a 15 year loan period) is also covered by national subsidy.

From Table IV it is clear that the most promising WG installation is the MICON 55-11 one. Due to its low capacity factor (about 10%) the economic assessment gives the following results:

TABLE IV. – Socio-economic impacts concerning the MICON 55-11 WG

IRR (%)	6,27
NPV (€)	925,11
BCR	1,048
PBP (years)	15,8
CoE (€/kWh)	0,14712
<i>Avoided conventional fuel</i>	
TOE/yr or	13,14
(Tons of avoided lignite)/yr or	76,4
(Nm³ of avoided natural gas)/yr	2247,6
<i>Avoided emissions</i>	
CO₂ (kgr)	38.209,15
SO₂ (kgr)	71,92
NO_x (kgr)	5,39
CO (kgr)	8
HC (kgr)	2,247
Particulates (kgr)	35,961

Due to the actual high initial capital cost of a PV installation it became clear from the investigation that it is non-profitable to install at the examined site either a PV or a hybrid WG/PV power plant.

4. Conclusion

In this paper the main system components of a practical small-scale hybrid Wind-Photovoltaic-Battery system installation were analytically modelled and investigated for the purpose of this work. To this effect a general computerized techno-economic assessment procedure was developed and used in the preliminary evaluation of the technical feasibility and financial viability of potential RES installations. The case study showed that the site under investigation is of relatively low energy potential and thus it is not suitable for possible installation exploitation.

The results of the economic assessment pointed out a) the significant role the applicable subsidy plays on an investment viability of the project, b) the resulting national benefit due to avoidance of imported oil and natural gas, and c) the significant beneficial influence it has on the environment, based on the decrease of the associated emissions/pollutants (e.g. Green House Gas emissions, acid rain, smog etc.) due to substitution of conventional fuel(s).

The developed systematic procedure offers a relatively easy computational approach to thoroughly study small-scale hybrid power systems, consisting of RES, and it could easily be applicable to assess medium or even large scale such power systems.

References

- [1] B.S. Borowy and Z.M. Salameh, "Methodology for Optimally Sizing the Combination of a Battery Bank and PV Array in a Wind/PV Hybrid System" IEEE Transactions on Energy Conversion, Vol. 11, No. 2, pp. 367-375, June 1996.
- [2] R. Chedid and S. Rahman, "Unit Sizing and Control of Hybrid Wind-Solar Power Systems" IEEE Transactions on Energy Conversion, Vol. 12, No. 1, pp. 79-85, March 1997.
- [3] K.Y. Khouzam, "Technical and Economic Assessment of Utility Interactive PV systems for Domestic Applications in South East Queensland" IEEE Transactions on Energy Conversion, Vol. 14, No. 4, pp. 1544-1550, December 1999.
- [4] A.D. Karlis, D.P. Papadopoulos and E. Vasiliadis, "Economic Assessment of Utility Interactive WECS and/or PVs for Auto-Producer Mode of Operation" in *Proc. ICERD-2*, Vol. I, pp. 97-107, 2002.
- [5] T. Tomtsi, "Technical and Economical Assessment – Exploitation of a Solar Generator System" (in Greek), M.Sc. thesis, Democritos University of Thrace, 2002.
- [6] M. Kohle et al., "Analytical model for predicting the performance of photovoltaic array coupled with a wind turbine in a stand-alone renewable energy system based on hydrogen" *Renewable Energy*, 28 (2003), pp. 727-742.